

Technical Information

Reference Number: GTX-S100

Title: Method for Shipment of Undisturbed Shelby Tube Samples

Sample Size: 3" outside diameter, 30" in length

Number of Samples: 3 maximum

Equipment: Base (A), Barrel (B), Packing Insert with pre-drilled holes (C), Packing Insert Top (D), Specialized Composite (E), Strapping and Buckle

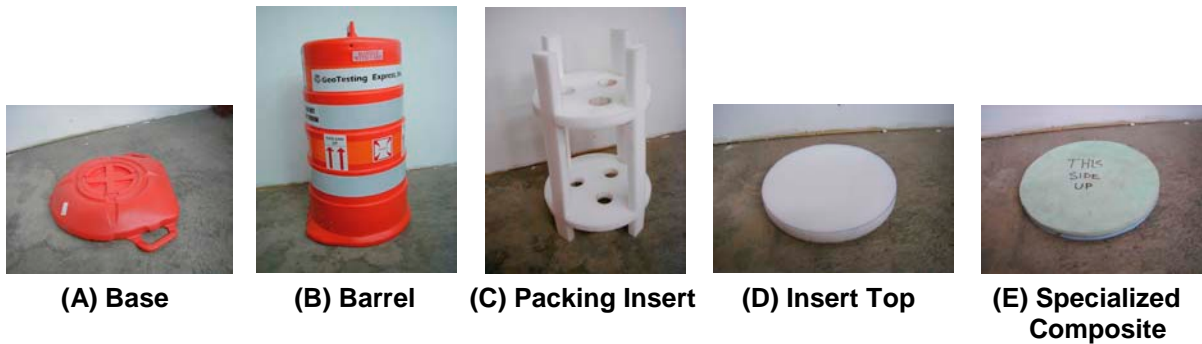

Standard Operating Procedure

1. Fill out a chain-of-custody form with a list of samples intended for shipment and the tests that are requested for each sample. Fax the form to the lab where samples will be delivered to provide early notification of sample arrival.
2. Open the empty shipping container by inverting then prying the base from the barrel with a screwdriver or similar object.



Fig. 1 Base & Specialized Composite

3. Prepare the Shelby tubes for shipping by clearly labeling each one and taping the end caps with electrical tape.
4. Place the Base on a flat surface and place the Specialized Composite material with marked side up on top of the Base as shown in Figure 1.



Fig. 2 Base, Specialized Composite and Packing Insert

5. Place the Packing Insert with pre-drilled holes on top of the Base as shown in Figure 2.

6. Place up to three undisturbed Shelby tubes into the pre-drilled holes of the Packing Insert. Tubes should be inserted bottom first through the top hole and guided down through the second hole. Tubes should come to rest on the Specialized Composite.
7. Once tubes are inserted, place the Packing Insert Top to rest on the top of the tubes as shown in Figure 3.
8. Place the chain-of-custody form and other pertinent project information on top of the assembly.
9. Place the Barrel over the entire assembly and press down to the Base as shown in Figure 4.



Fig. 3 Packing Insert with Shelby Tubes and Packing Top

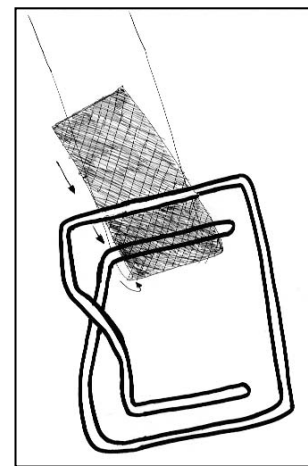

Fig. 4 Placing Barrel over Packing Insert

10. Snap the Barrel into place by pressing down on the straight side first, then rock the Barrel forward to snap into place (this will take some downward force to snap).
11. Use strapping provided to loop through two holes on top of Barrel and two handles on Base (see Diagram 1). Situate the buckle of the strapping at the top of the Barrel.
12. Fill out the proper shipping labels and affix to the top of the container. GeoTesting Express addresses are shown below.

MASSACHUSETTS
 GeoTesting Express, Inc.
 1145 Massachusetts Avenue
 Boxborough, MA 01719
 Phone: 978-635-0424
 Fax: 978-635-0266
 e-mail: gtt@geotesting.com

GEORGIA
 GeoTesting of Georgia, Inc.
 2662 Holcomb Bridge Road
 Suite 310
 Alpharetta, GA 30022
 Phone: 770-645-6575
 Fax: 770-645-6570
 e-mail: jwang@geotesting.com



Dia. 1 Buckle and Strapping