

Iowa DOT/FHWA – Column Supported Embankment

Technologies to manage risk for infrastructure

The Iowa DOT together with the FHWA commenced a research project in May 2004 to validate the design methods for column-supported embankments (CSE). The project comprised two full-scale test sections in a new highway embankment on I-295 located in Des Moines, Iowa.

The objectives of the instrumentation program for the column-supported embankment are to:

- provide data on the performance of the CSE that may be used to calibrate a numerical model used to evaluate the design parameters
- develop modular instrumentation program to



Resistance strain gauge mounted on a steel H-pile.

of the embankment and all instrumentation wiring is run directly to the centralized logger location.

Each of the loggers are powered by internal battery packs and backed up by deep cell marine batteries to provide constant power to the units for a period of up to two months. This allows for minimal maintenance of the data collection system and cost the client.

Geocomp has been using its iSiteCentral web-based reporting

be used to obtain similar information on other CSE Projects

- provide an instrumentation program that has the capability for data to be available to engineers in real time via the Internet.



Data loggers in custom built housing with back up power.

The instrumentation used to monitor the performance of the Production and Research test sections consists of:

- 48 Resistive Strain Gages mounted on both geotextiles and steel H-piles
- 24 VW Settlement Cells
- 6 VW Earth Pressure cells.

service to present all data for the project. iSiteCentral provides a World Wide Web location where all data is loaded and reduced in real time and can be viewed by all FHWA and Iowa DOT authorized users. The system has been operating successfully for over 6 months and has recorded better than 28,000 readings.

Geocomp furnished ten 8-channel data loggers along with two cell phone portal units to provide data collection and transmittal. The loggers are housed in a custom-built foot locker located at the top

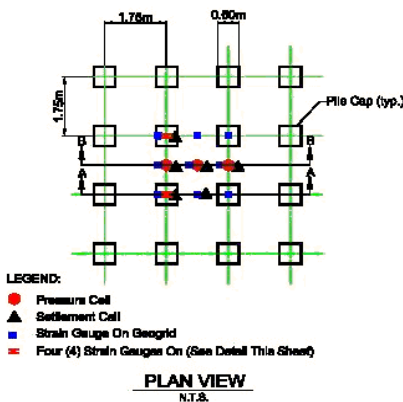

Production Section

Test Section 1.